



# TOYOTA

Toyota Motor Sales, U.S.A., Inc.  
19001 S. WESTERN AVE.  
P.O. BOX 2991  
TORRANCE, CA 90509-2991  
(310)618-4000  
(310)618-7800 Fax

TO: ALL TOYOTA DEALER PRINCIPALS,  
SERVICE MANAGERS, PARTS MANAGERS

SUBJECT: SPECIAL SERVICE CAMPAIGN – S02  
(1993 and 1994 LAND CRUISER O<sub>2</sub> SENSOR)

**Toyota will initiate a Special Service Campaign to replace the O<sub>2</sub> sensors on 1993 and 1994 model year Toyota Land Cruisers.**

Toyota has determined that the oxygen sensor heater wire on the vehicle may have an open circuit due to repeated thermal stress, causing the Malfunction Indicator Lamp (MIL) to illuminate.

Please be sure to perform the necessary inspection and/or repair on any vehicles acquired in your inventory prior to sale or lease of the vehicle.

1. Owner Notification Letter Mailing Date

August, 1995 (copy attached)

2. Identification of Involved Vehicles

Year	Model	VIN Range	
		VDS	Ranges
1993 and 1994	Land Cruiser	JT3DJ81W	0011806 thru 0093518

**Note:** Although the involved vehicles are within the above VIN ranges; not all vehicles in these ranges were imported into the U.S.

Should you be contacted by the owner of an involved vehicle who has not yet received a notification, please verify eligibility by referring to the VIN range and perform the necessary modification.

3. Repair Procedures

Refer to the attached Technical Instructions.

4. Parts Ordering

Necessary parts must be ordered from your facing Parts Distribution Center. **In order to avoid excessive parts orders and maintain adequate parts inventory, your initial parts order should not exceed 10% of the number of involved vehicles listed in your PMA Dealer/owner list (SSC S02).**

Part Number	Description	Qty/Vehicle	Comment
89465-60110	O <sub>2</sub> Sensor Kit	1	Contents: 1 RH O <sub>2</sub> sensor 1 LH O <sub>2</sub> sensor 2 O <sub>2</sub> sensor gaskets 4 nuts
90917-06065	Exhaust Pipe Gasket	2	For the No. 1 & No. 2 exhaust manifold front exhaust pipes
90179-10070	Exhaust Pipe Nut	4	
90917-06076	Exhaust Pipe Gasket	2	For the three-way catalytic converter No. 3 front exhaust pipe

Reimbursement Procedures

Submit Special Service Campaign claims following the procedures described in the Toyota Warranty Policy & Procedures Manual.

The operation codes to be used for this campaign are as follows:

SSC#	Op. Code	Description	Flat Rate Hour
S02	5519F1	Replacement of oxygen sensor	1.1 hrs/veh

**NOTE:** The above flat rate time includes 0.1 flat rate hour for administrative expense. Please review this entire package with your Service and Parts staff to familiarize them with the proper step-by-step procedure and implement this Special Service Campaign to ensure customer satisfaction.

Thank you for your cooperation.  
TOYOTA MOTOR SALES, U.S.A., INC.

## **SSC S02 – TOYOTA LAND CRUISER OXYGEN SENSOR SPECIAL SERVICE CAMPAIGN NOTICE**

Dear Toyota Owner:

This notice is being sent to inform you that your 1993 or 1994 model Land Cruiser may encounter a condition where the Malfunction Indicator Lamp may illuminate due to an open circuit of the oxygen sensor heater.

### **WHAT IS THE PROBLEM?**

The heater element in the oxygen sensors on your vehicle may fail prematurely causing the Malfunction Indicator Lamp to illuminate. If this condition is not corrected, the vehicle may not be able to pass the smog inspection required in your state.

### **WHAT SHOULD YOU DO?**

Any Toyota dealer will install improved oxygen sensors to prevent this condition at **NO COST** to you.

### **WHAT SHOULD TOYOTA DO?**

Contact any authorized Toyota dealer and make an appointment to have the repair performed as soon as possible.

The labor time for installation of the improved oxygen sensors is approximately 1 hour. However, depending upon the dealer's work schedule, it may be necessary to make your vehicle available for a longer period of time.

**Please present this notice to the dealer when you bring the vehicle in for the repair.**

If you no longer own the vehicle, please indicate so on the enclosed postage paid form, providing us with the name and address of the new owner.

### **WHAT IF YOU HAVE OTHER QUESTIONS?**

Please contact any Toyota dealer or call the Toyota Customer Assistance Center at 1-800-331-4331.

We have sent this notice in the interest of your continued satisfaction with our products and we sincerely regret any inconvenience this condition may have caused you.

Thank you for driving a Toyota.

Sincerely,

TOYOTA MOTOR SALES, U.S.A., INC.  
CORPORATE SERVICE DEPARTMENT

**TECHNICAL INSTRUCTIONS**  
**FOR**  
**SPECIAL SERVICE CAMPAIGN S02**

**I. OPERATION FLOW CHART**

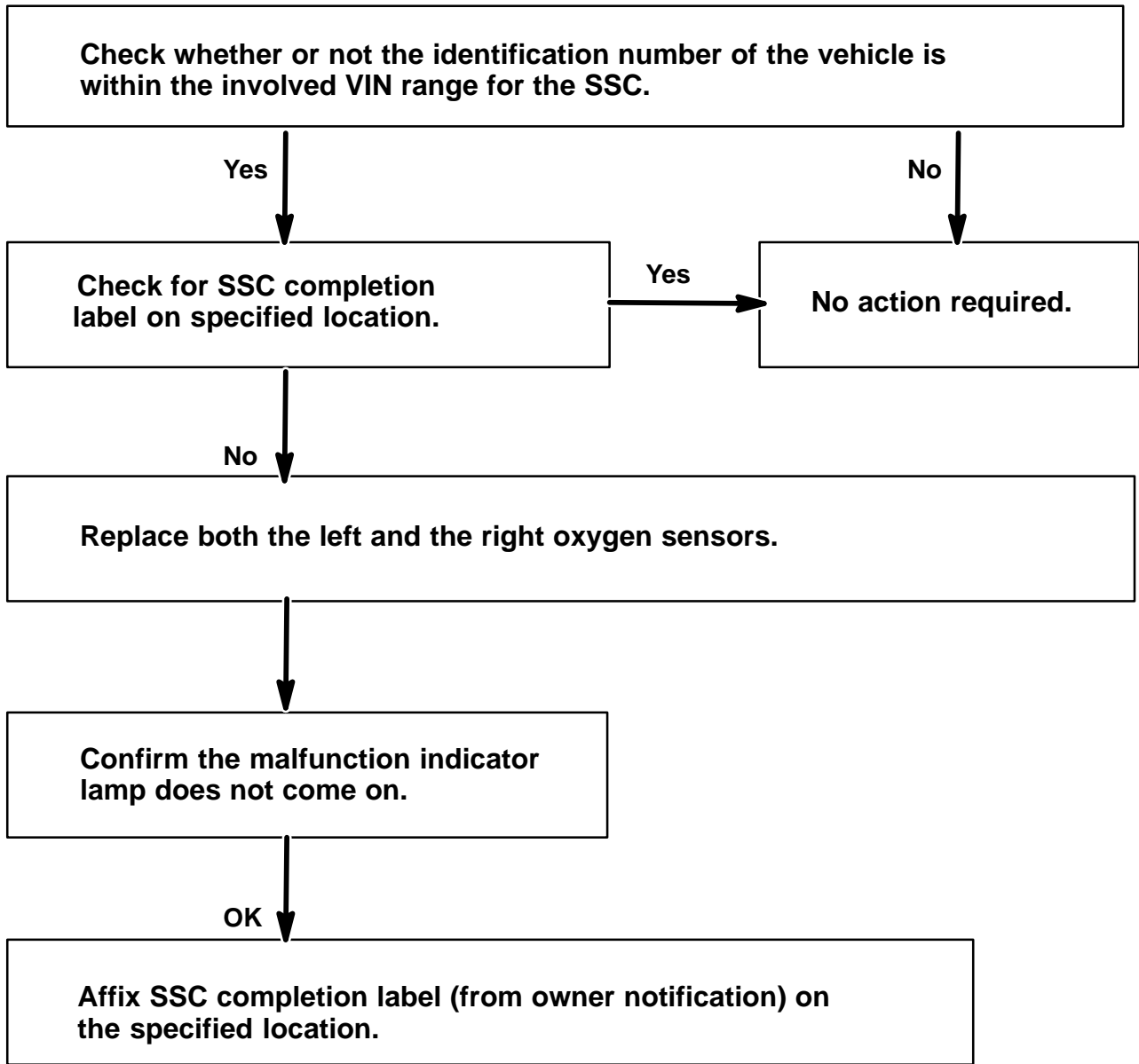

### **III. LOCATION OF AFFECTED PARTS**

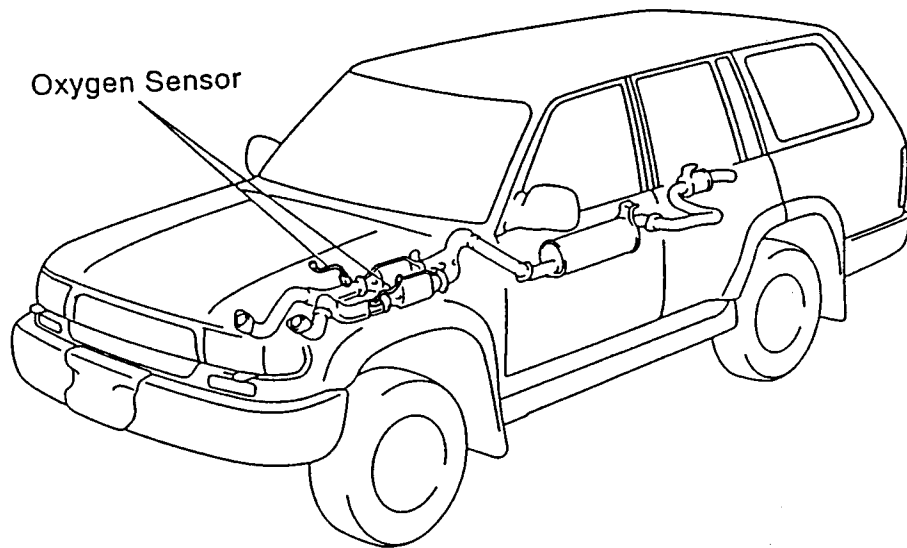

### **III. PREPARATION**

#### (1) NECESSARY TOOLS

Part Number	Description	Qty/Vehicle	Comment
89465-60110	O <sub>2</sub> Sensor Kit	1	Contents: 1 RH O <sub>2</sub> sensor 1 LH O <sub>2</sub> sensor 2 O <sub>2</sub> sensor gaskets 4 nuts
90917-06065	Exhaust Pipe Gasket	2	For the No. 1 & No. 2 exhaust manifold front exhaust pipes
90179-10070	Exhaust Pipe Nut	4	
90917-06076	Exhaust Pipe Gasket	2	For the three-way catalytic converter No. 3 front exhaust pipe

#### **2. NECESSARY TOOLS**

- Torque Wrench
- Standard Tools

## IV. WORK PROCEDURE

1. CHECK THAT THE IGNITION KEY IS EITHER AT OFF POSITION OR IS PULLED OUT.
2. JACK UP THE VEHICLE.
3. DISCONNECT BOTH OXYGEN SENSOR CONNECTORS.

- (a) For the right-side oxygen sensor, remove the clip and disconnect the oxygen sensor from the body.

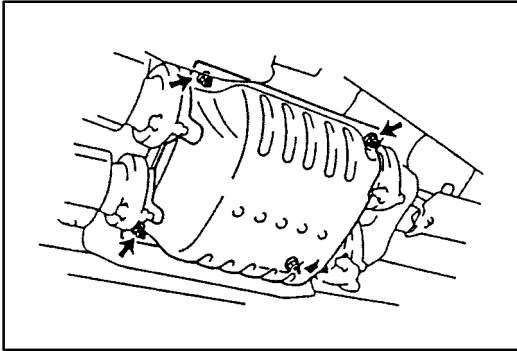

### 4. REMOVE FRONT EXHAUST PIPE.

- (a) Remove the 4 nuts and the lower converter insulator cover.

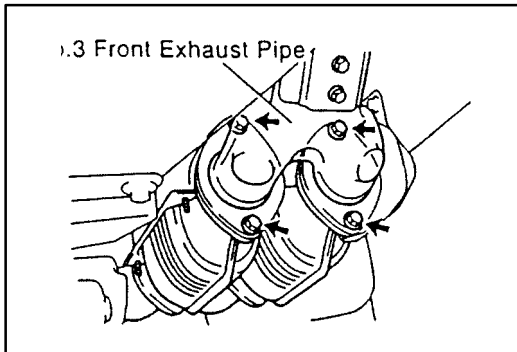

- (b) Remove the 4 bolts, 2 nuts, retainer and disconnect the three-way catalytic converter from the No. 3 front exhaust pipe assembly.

NOTE: If corrosion renders the exhaust bolts and nuts non-reusable, following are the necessary part numbers:

Bolt: 91511-61035 Nut: 94180-41000

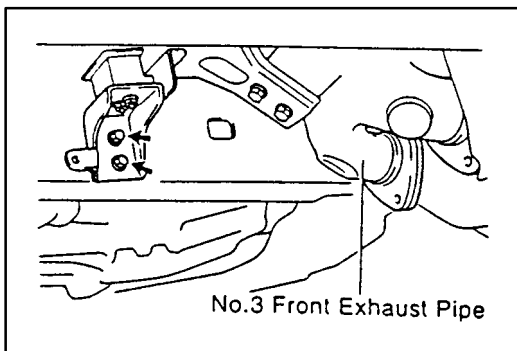

- (c) Remove the 2 bolts to disconnect the No. 3 front exhaust pipe assembly from the frame.

- (d) Loosen the clamp bolt and disconnect the clamp from the No. 1 support bracket.

NOTE: Clamp bolt: 91621-60835

- (e) Remove the 2 nuts and the No. 2 front exhaust pipe assembly from the No. 2 exhaust manifold.

NOTE: Manifold stud bolt: 90126-10006

- (f) Remove the gasket from the No. 2 front exhaust pipe assembly.

- (g) Remove the upper converter insulator cover.

- (h) Remove the 2 nuts and the No. 1 front exhaust pipe assembly from the No. 1 exhaust manifold.

- (i) Remove the gasket from the No. 1 front exhaust pipe assembly.

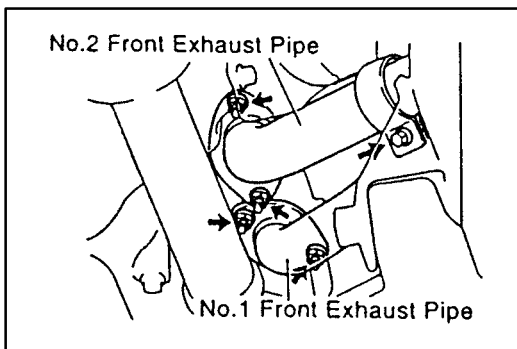

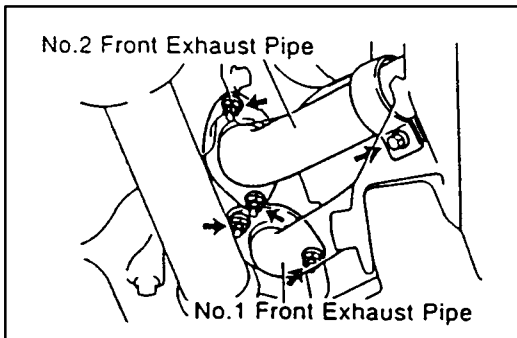
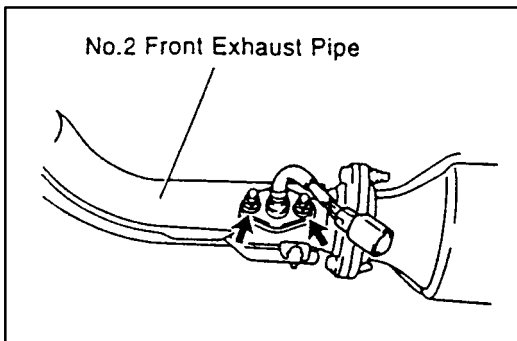
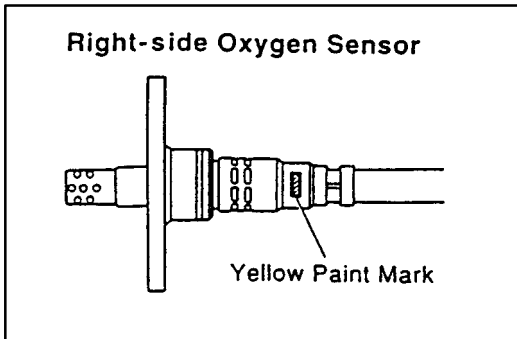
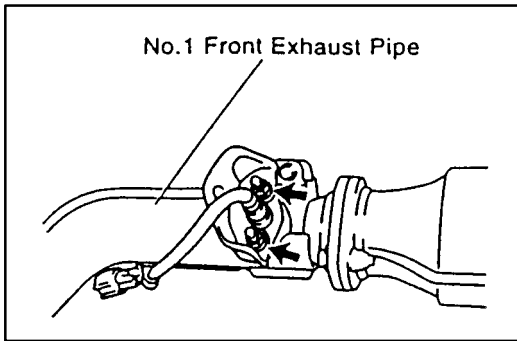

## 5. REPLACE OXYGEN SENSOR.

(a) Remove the 2 nuts, oxygen sensor cover, oxygen sensor and gasket from the No.1 front exhaust pipe assembly.

(b) Install a new gasket, right-side oxygen sensor (indicated by a yellow paint mark as shown in the illustration), and the oxygen sensor cover to the No. 1 front exhaust pipe assembly with 2 new nuts.

Torque: 20 N•m (200 kg-cm, 14 ft-lb)

(c) Remove the 2 nuts, oxygen sensor and gasket from the No. 2 front exhaust pipe assembly.

(d) Install a new gasket and left-side oxygen sensor to the No. 2 front exhaust pipe assembly with 2 new nuts.

Torque: 20 N•m (200 kg-cm, 14 ft-lb)

## 6. REINSTALL FRONT EXHAUST PIPE.

(a) Install a new gasket to the No. 1 front exhaust pipe assembly.

(b) Reinstall the No. 1 front exhaust pipe assembly to the No.1 exhaust manifold with 2 new nuts.

Torque: 62 N•m (630 kg-cm, 46 ft-lb)

(c) Reinstall the upper converter insulator cover.

(d) Install a new gasket to the No. 2 front exhaust pipe assembly.

(e) Reinstall the No. 2 front exhaust pipe assembly to the No. 2 exhaust manifold with 2 new nuts.

Torque: 62 N•m (630 kg-cm, 46 ft-lb)

(f) Clamp the No. 2 front exhaust pipe to the No. 1 support bracket with the clamp bolt.

Torque: 19 N•m (195 kg-cm, 14 ft-lb)



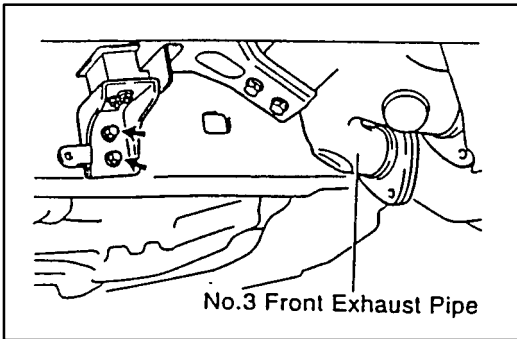

(g) Tighten the 2 bolts as shown in the illustration.

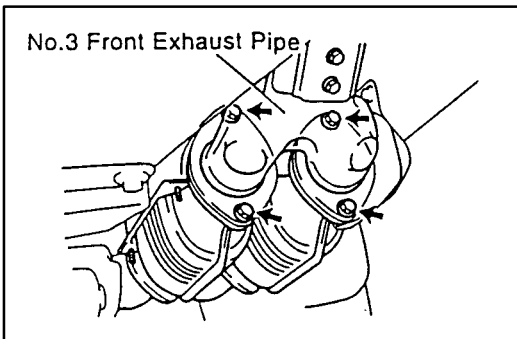

(h) Install 2 new gaskets to the No. 3 front exhaust pipe assembly and reconnect that to the three-way catalytic converter with 4 bolts, 2 nuts and retainer.

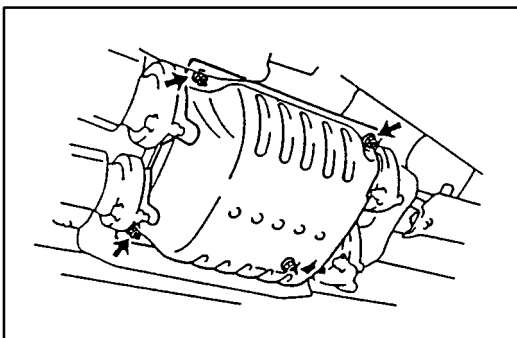

(i) Reinstall the lower converter insulator cover with 4 nuts.  
Torque: 11 N•m (110 kg-cm, 8 ft-lb)

**7. RECONNECT BOTH OXYGEN SENSOR CONNECTORS.**

(a) For the right-side oxygen sensor, reinstall the clip and reconnect the oxygen sensor to the body.

**8. USE THE IGNITION KEY TO START THE VEHICLE, MAKE SURE THAT THE MALFUNCTION INDICATOR LAMP DOES NOT ILLUMINATE.**

**9. SSC COMPLETION LABEL INSTALLATION**

(a) After completing repair and before returning vehicle to the owner, a SSC completion label that is enclosed in the owner's notification must be affixed to the left front door hinge post near the check strap.

(b) The label is to be filled out as follows:

- Write in SSC S02
- Write in date of repair
- Write in your Dealer Code

SSC	Date
TOYOTA MOTOR SALES, U.S.A., INC.	
DEALER CODE NO.	
00410-01917	

(c) Additional SSC completion labels, in sheets of 50 (P/N 00410-01917), may be ordered through the non-parts system on a 1450 order form or through the TDN system.